

---

## **Substation Retrofit for Total IEC 61850 MMS Solution**

**A regional substation wanted to enhance the monitoring of their existing legacy infrastructure to prevent outage. Moxa's NPort S9650I serial device servers support IEC 61850 MMS to implement the IEC 61850 substation retrofit.**

---

A regional substation was tasked with improving the substation's performance and reducing maintenance problems, but without replacing several key serial IEDs already in operation. Because the many RTUs, HMIs, switches, and IEDs installed in the substation were from different vendors and some used proprietary protocols, several different drivers had to be installed to allow the power SCADA system to manage the entire substation. A key part of the solution was to upgrade or replace the existing SCADA system, RTUs, HMIs, and switches to support the IEC 61850 MMS protocol and thereby achieve unified MMS monitoring and vendor-independent maintenance. In order to keep the existing serial IEDs connected to the system, RTUs were considered for connecting the legacy Modbus and DNP3 IEDs to the substation's network.

### **System Requirements**

- 
- Use IEC 61850 communication for power SCADA supervision
  - High-port density of serial connections to network the existing Modbus and DNP3 legacy IEDs to the substation network
  - Robust reliability to withstand harsh EMI conditions

## **Moxa's Solution**

Instead of using RTUs, the system integrator found that Moxa's NPort S9650I was a perfect solution for connecting the aging, legacy IEDs to the substation's IEC 61850 network. Since the NPort S9650I serial device servers support the IEC 61850 MMS protocol, they can be monitored by the power SCADA system. The NPort S9650I provides up to 16 serial ports to connect existing Modbus and DNP3 IEDs, and uses the MMS protocol to communicate with both the power SCADA system and RTUs to report the status of legacy IEDs, such as turning a modem on or off, keeping track of TX/RX counts, etc.

The NPort S9650I supports both the IEEE 1588 protocol and IRIG-B time synchronization, making it possible to construct a timeline of events for troubleshooting purposes. The NPort S9650I can obtain the precise time from the IEEE 1588 protocol (via an Ethernet port) or IRIG-B time server (via a BNC connector) and then send the signals over the serial connections to synchronize the serial IEDs with the rest of the network.

After the substation's Ethernet equipment was upgraded to a total MMS solution, the power SCADA system could use the unified MMS interface to monitor all of the substation's various Ethernet devices, regardless of brand. In fact, the NPort S9650I's serial-to-Ethernet capability and support of the MMS protocol allowed the substation's power SCADA system to monitor the status of all the substation's legacy serial IEDs in addition to the Ethernet-based devices.

## **Why Moxa?**

- The NPort S9650I supports unified IEC 61850 MMS communication to bridge a legacy infrastructure to an IEC 61850 network
- Modbus/DNP3 protocol gateway with up to 16 serial ports for a cost-effective network retrofit
- Dual power inputs and IEC 61850-3 compliance for robust performance

## Using RTUs to connect legacy IEDs

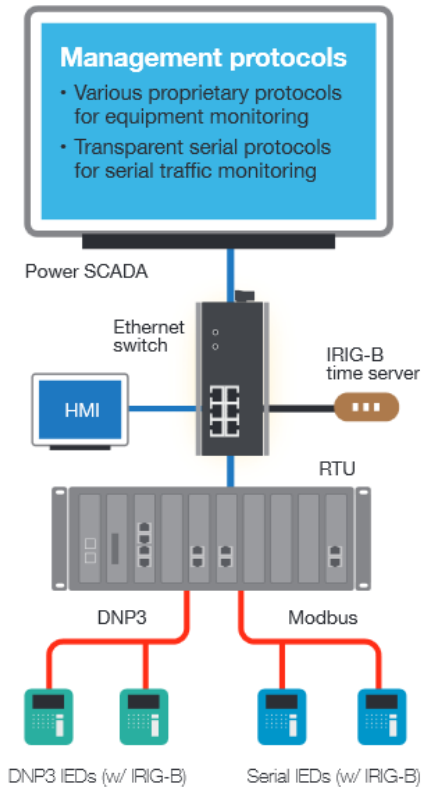

## Using the NPort S9650I to connect legacy IEDs

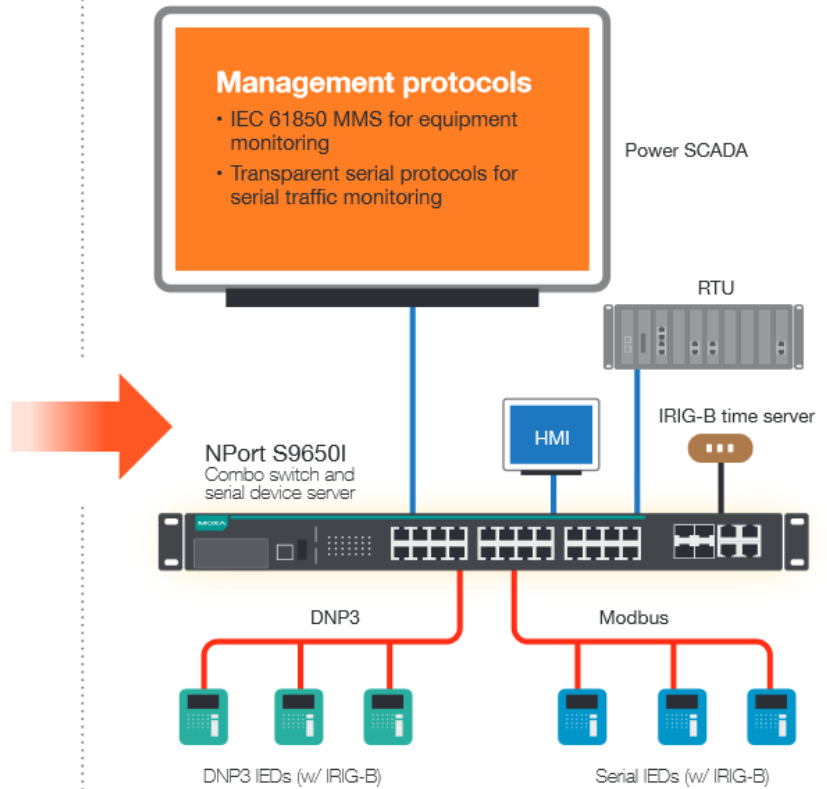

— Ethernet for IEC 61850 MMS    — Serial Modbus / DNP3    — Coaxial for IRIG-B TTL



### ***NPort S9450I/S9650I Series*** **IEC 61850 Combo Switch** **and Serial Device Server**

- 4, 8, or 16 serial port serial connections
- 2 or 4 managed Ethernet switch ports
- Supports Ethernet, DNP3, and Modbus protocols
- Supports the IEC 61850 MMS protocol
- IEC 61850-3 and IEEE 1613C1D2\* compliant
- Supports IEEE 1588v2 and IRIG-B for time synchronization\*\*
- IEC-62443 standards supported for better cybersecurity

---

		<ul style="list-style-type: none"><li>• -40 to 85°C wide operating temperature</li></ul> <p>* C1D2 is available with NPort S9450I only</p> <p>** Time synchronization is available with NPort S9650I only</p>
--	--	---